



MOFÉM



Gyártó/Forgalmazó:
STROHM MOFÉM Zrt.
9200 Mosonmagyaróvár Terv u. 92.

EN ISO 9001:2015

Automata mosdó csaptelep
hideg vagy kevert vízhez 6V
Washbasin tap for cold or premixed water, 6 V

MLU-01NB6

Használati útmutató

EN Instructions for use
DE Gebrauchsanleitung
ES Instrucciones de uso

RU Инструкция по эксплуатации
RO Instrucțiuni de utilizare
LT Naudojimosi instrukcija

CZ Návod na použití

Általános funkciók

EN Function
DE Funktion
ES Función estándar

RU СТАНДАРТНАЯ программа
RO Funcționare în regim STANDARD
LT STANDARTINĖ programa

CZ STANDARDNÍ funkce

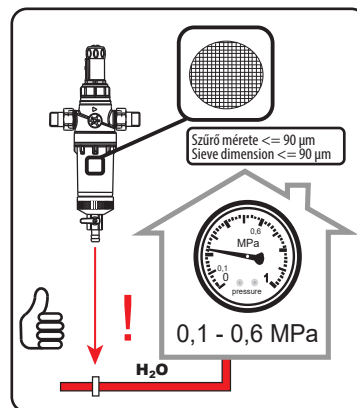
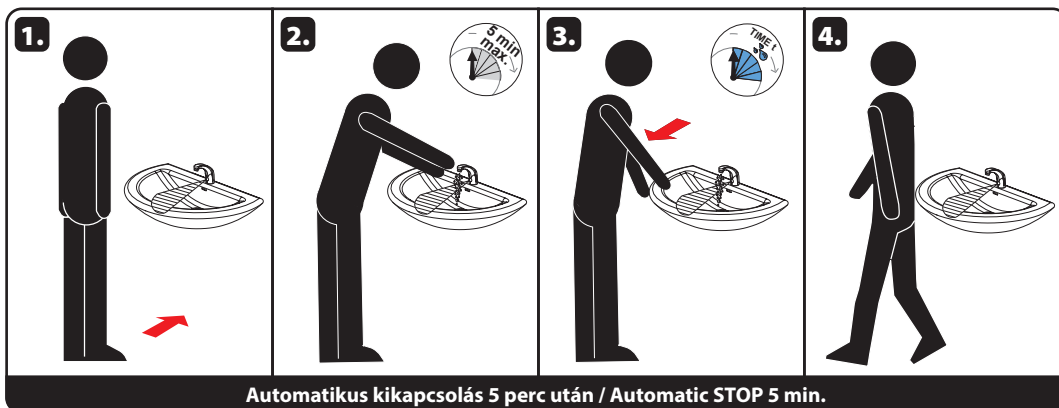

Műszaki paraméterek

EN Properties
DE Eigenschaften
ES Características

RU Технические характеристики
RO Proprietăți
LT Techninės charakteristikos

CZ Vlastnosti

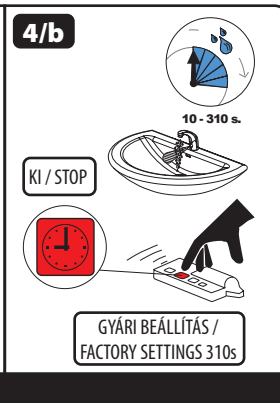
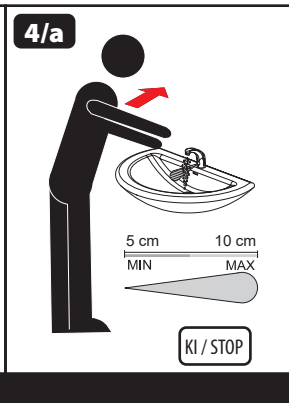
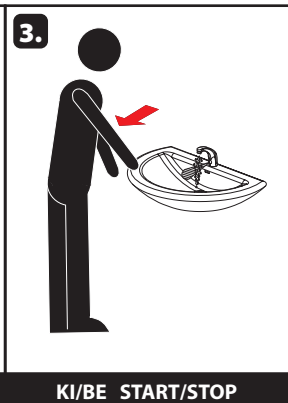
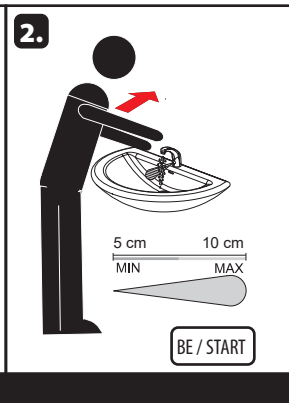
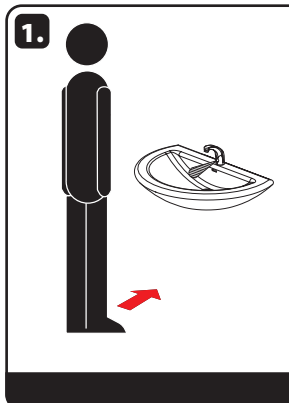
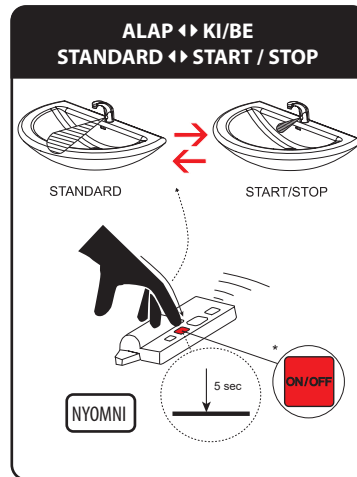
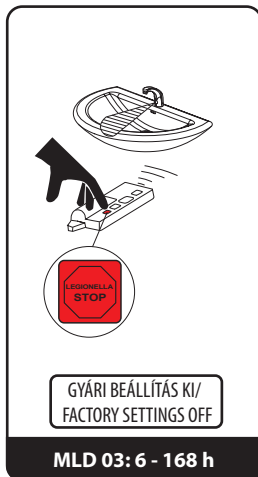
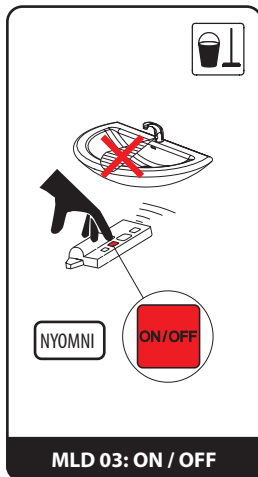
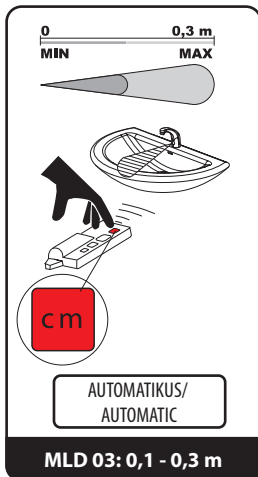

KI/BE START/STOP



Szerelési útmutató

EN Mounting instructions
D/A Montageanleitung
ES Manual de instrucciones

RU Инструкция по монтажу
RO Instrucțiuni de montaj
LT Montavimo instrukcija

CZ Montážní návod

Csomag tartalma

EN Supplied equipment
D/A Lieferumfang
ES Especificación de suministro

RU Спецификация поставки
RO Componente livrate
LT Tiekimo specifikacija

CZ Specifikace dodávky

MLU-01NB6 - 753082800

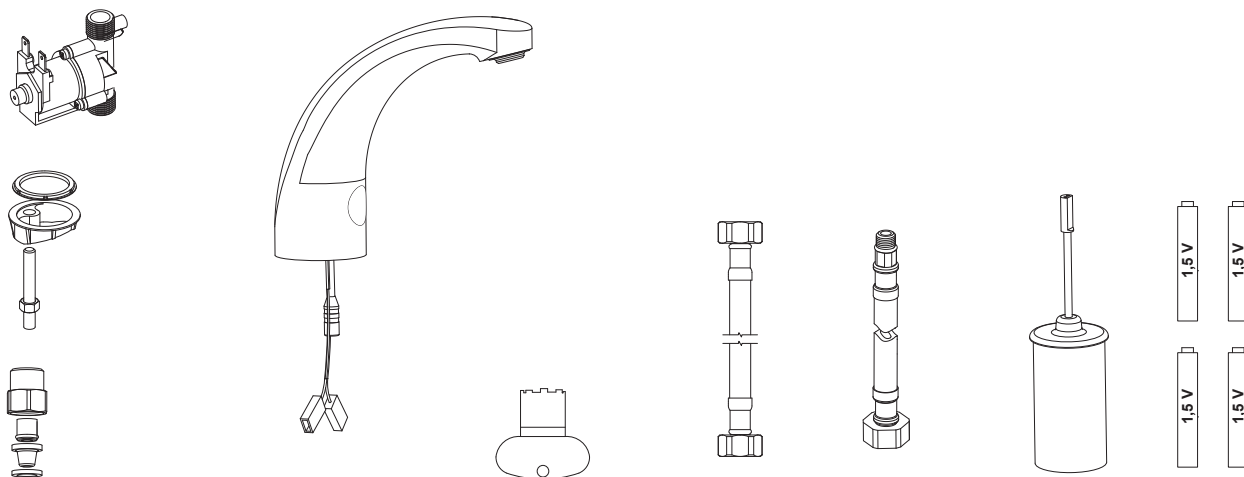

Telepítés

EN Installation
D/A Installation
ES Instalación

RU Схема включения и монтажа
RO Instalare
LT Montavimo ir įjungimo schema

CZ Instalace

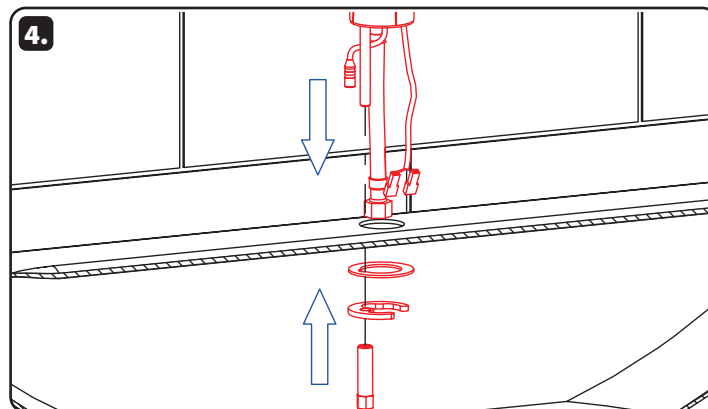
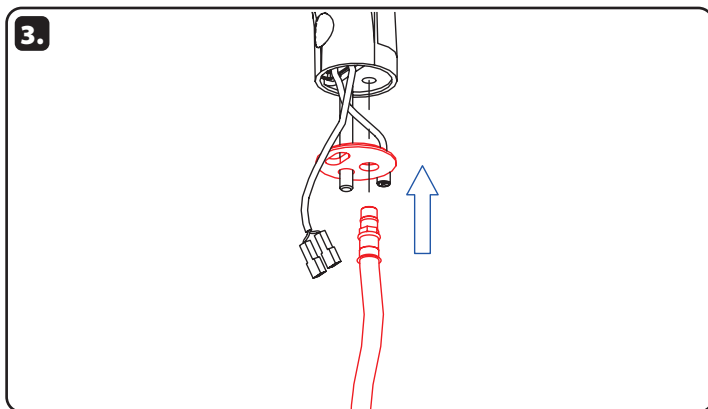
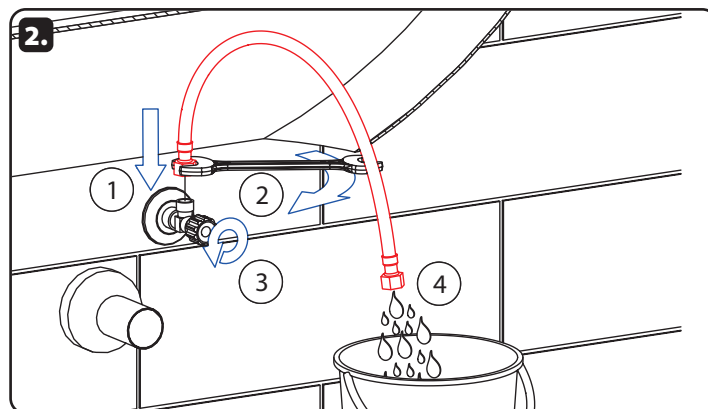
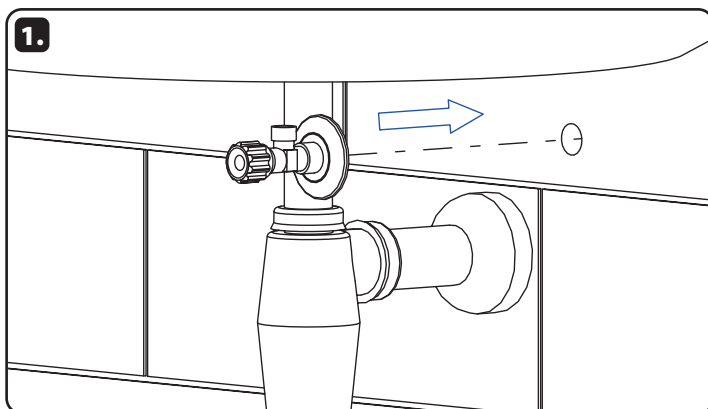

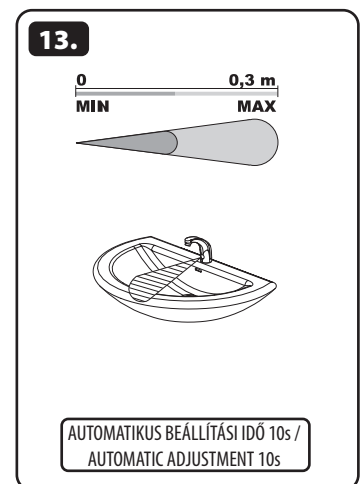
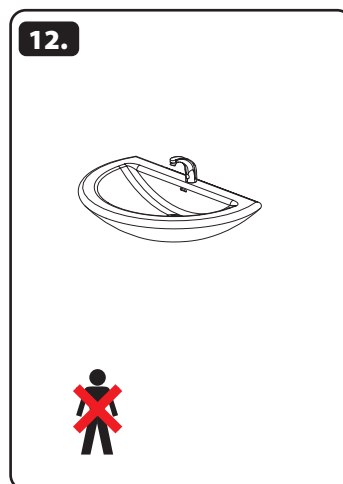
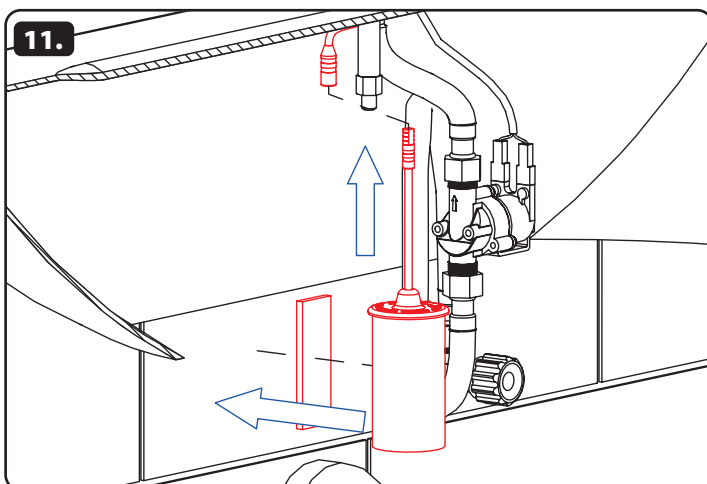
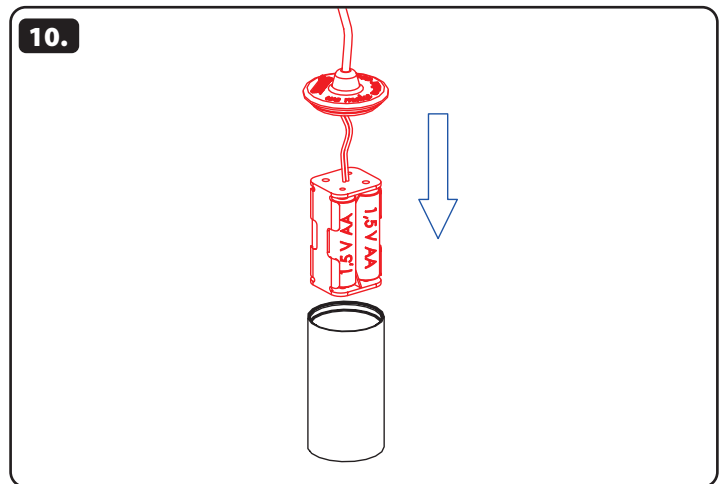
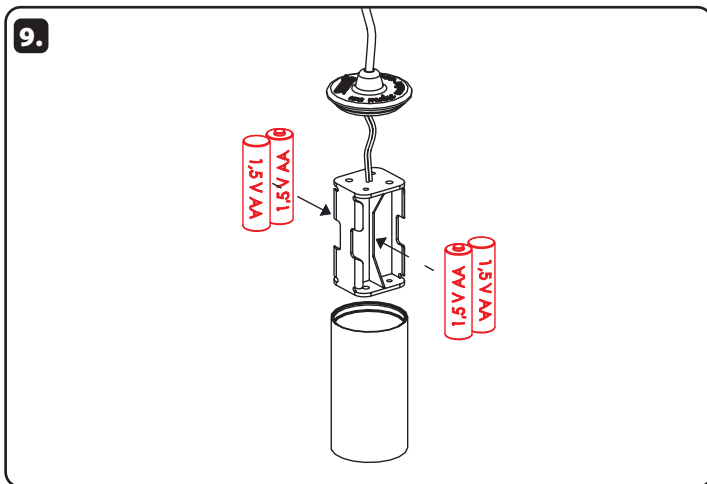
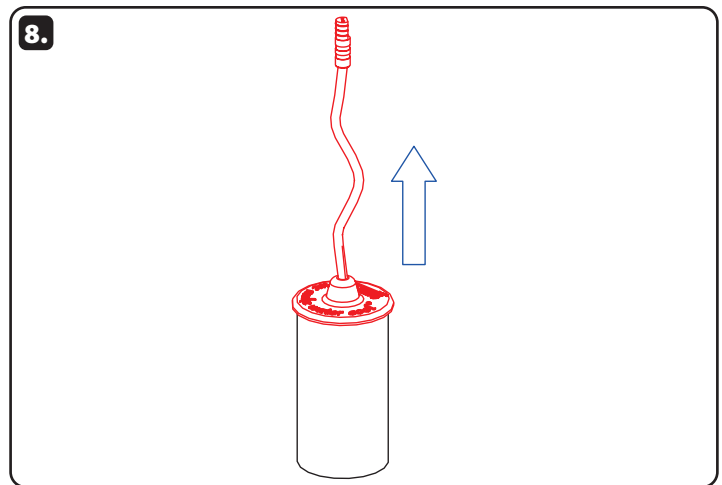
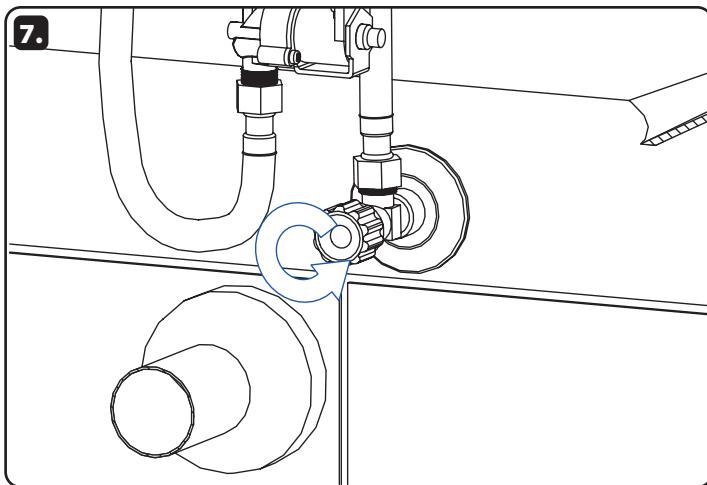
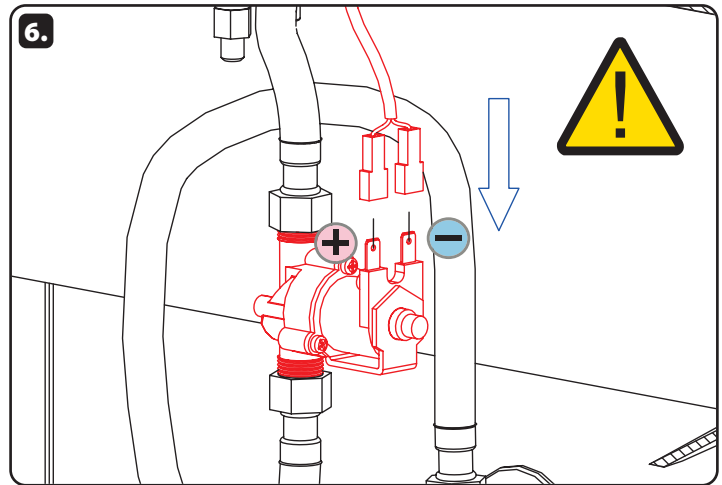
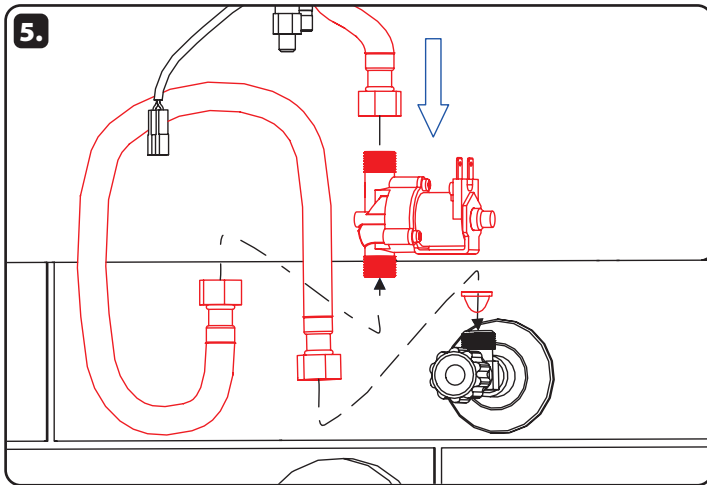



**Akkumulátor állapot visszajelzés**

EN Battery capacity control
DE Batteriezustandsanzeige
ES Control de la capacidad de la batería

RU Проверка состояния питающей батареи
RO Controlul capacității bateriei
LT Maitinimo baterijos patikrinimas

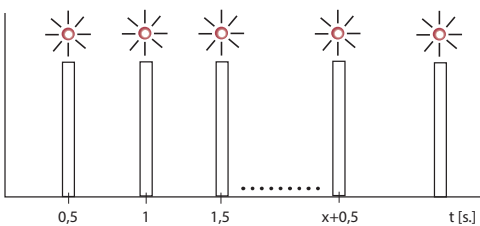
CZ Kontrola stavu napájecí baterie

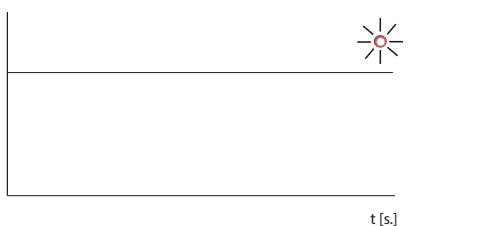
	JELZÉS / INDICATION	ELEKTRONIKUS RENDSZER / ELECTRONIC SYSTEM	AKKUMULÁTOR CSERE / BATTERY EXCHANGE
 10 - 0 % KAPACITÁS / CAPACITY		BE / ON	AJÁNLOTT / RECOMMENDED
 0 % KAPACITÁS / CAPACITY		KI / OFF	SZÜKSÉGES / NECESSARY

Karbantartási útmutató

EN Instructions for maintenance
DE Wartungsanleitung
ES Instrucciones de cuidado

RU Инструкция по уходу
RO Instrucțiuni de întreținere
LT Prižiūros instrukcija

CZ Návod na údržbu

Karbantartási útmutató

Javasolt a mágnesszelep szűrőjét évente egyszer tisztítani, mert elszennyeződhet. Ajánlott évente egyszer ellenőrizni a csavarkötések állapotát, valamint az érintkező felületeket. A csomagoló anyagokat a szabályok betartásával helyezze el miután kicsomagolta a terméket. Jelen termék gyártója tanúsítja, hogy a termék megfelel a 73/023/EEC és 89/336/EEC rendelkezéseinek.

Instructions for use

It is recommend to check up the sifter of electromagnetic valve once a year, because of there is a possibility that valve could be fouled up. Checking of tightening of screw connections and connectors contact surfaces is also recommend once a year. It is necessary to proceed according to the law about packaging material after unpacking of the product. Producer assures that this product has declaration of conforminty in accordance with the regulation 73/023/EEC and 89/336/EEC.

Gebrauchsanleitung

Wegen der Möglichkeit, daß Ventil mit Schmutz vom Wasser verstopft kann sein, wird empfohlen, 1-mal pro Jahr Kontrolle des Siebes des elektromagnetischen Ventils, Nachziehung der Schraubverbindungen und Aufsitzflächen der Anschlüsse durchführen. Dies ist erforderlich auf der Grundlage der gesetzlichen Bestimmungen für die Rücknahme und/oder Entsorgung von Verpackungsmaterial. Wir, SANELA spol. s r.o. erklären dass dieser Product ist in Übereinstimmung mit die nächste Norm: 73/023/EEC und 89/336/EEC.

Instrucciones de uso

Dada la posibilidad de obstrucción de la válvula por las impurezas del agua se recomienda llevar a cabo el control anual (una vez por año) del cedazo de la válvula de solenoide, el apretado de las conexiones de tornillo y las superficies del apoyo del conector. Después de desembalar el producto es necesario proceder con el embalaje en acuerdo con la ley de los embalajes. El productor asegura que este producto tiene declaración de conformidad de acuerdo con la ley núm. 73/023/EEC y 89/336/EEC.

Инструкция по эксплуатации

Учитывая возможность засорения вентиля грязью, приносимой водой, рекомендуется 1 раз в году выполнить контроль состояния сетки электромагнитного вентиля, дотянуть резьбовые соединения и зажимы конькторов. Утилизация упаковочного материала должна производиться в соответствии с законом. Производитель подтверждает, что у этого изделия есть Декларация Соответствия в соответствии с нормами 73/023/EEC и 89/336/EEC.

Instrucțiuni de utilizare

Recomandăm curățirea fitrelor și a electrovalvei cel puțin o dată pe an, impuritățile din apă pot bloca electrovalva. Este recomandată și verificarea conexiunilor electrice, curățirea contactelor și strângerea șuruburilor. Gestionarea ambalajelor se va realiza conform legislației în vigoare. Producătorul garantează că aceste produse au declarații de conformitate care respectă reglementările 73/023/EEC și 89/336/EEC.

Naudojimosi instrukcija

Kadangi ventilis gali užsiteršti vandenyje esančiais nešvarumais, patariame kartą per metus išvalyti elektromagnetinį ventilių, patikrinti varžtelių įvėržimą ir nuosėdas ant jungčių. Išpakavus produktą būtina laikytis taisyklių atsižvelgiant į medžiagą, iš kurios pagaminta pakuotė. Gamintojas garantuoja, kad šis produktas turi atitiktis deklaraciją pagal reglamentą 73/023/EEC ir 89/336/EEC.

Návod na údržbu

Vzhledem k možnosti zanesení ventilu nečistotami z vody je doporučeno provést 1x ročně kontrolu sítka elektromagnetického ventilu, dotažení šroubových spojů a dosedacích ploch konektorů. Po vybalení výrobku je nutné s obalem postupovat podle zákona o obalech. Výrobce ujišťuje, že na výrobek je vydáno prohlášení o shodě v souladu se zákonem č. 22/1997 Sb

Ajánlott kiegészítők

MLA 36 4 darab alkáli elem, AA típus, 1,5 V, 2700 mAh
MLD 03 univerzális távirányító az infravörös szenzor beállításához
10.893.00 Y bekötő egységcsomag - lehetővé teszi a csaptelep hideg és meleg vízhálózatra való csatlakozását

Recommended accessories

MLA 36 set of 4 pcs. of alkaline batteries AA type, 1,5 V, 2700 mAh
MLD 03 universal remote control for setting of infra-red sensors
10.893.00 Y connection set - Enable to connect the mixers to cold and pre-mixed water network